

MPPT-10

Solar Charge Controller with
Maximum Power Point Tracking



Installation & Operation Manual

Content

1. Safety Instructions	3
2. MPPT Controller Instructions	3
2.1 Overview	3
2.2 Structure	4
2.3 Functions	4
2.4 MPPT technology Instructions	6
3. PV System Planning Reference	8
3.1 System Voltage	8
3.2 Solar Modules Configuration	8
3.3 Wire Sizing	9
3.4 Over Current Protection	10
3.5 Lightning Protection	10
3.6 Grounding	11
3.7 System Expansion	11
4. Installation	11
4.1 Dimensions	11
4.2 Connecting Diagram	12
4.3 Wiring	12
4.4 Installation Process	13
5. Operation Instructions	13
5.1 Button Function	13
5.2 LED Displays	14
5.3 System Voltage Indication	14
6. Faults and Remedies	14
6.1 Protection Remedies	15
6.2 Common Faults and Remedies	16
7. Technical Data	17
8. Quality Assurance	18

Dear Consumer:

Thank you very much for using our product! We will offer you the permanent and reliable service for your solar system!

The manual gives important recommendations for installing and using the MPPT controller. Please read the manual carefully and thoroughly before using this product.

1. Safety Instructions

- (1) The controller is only designed to be connected to the off-grid solar system. It offers the management of charging and discharging for the lead-acid battery of flooded, gel and AGM chemistries from 12V to 24V nominal only. Do not connect this controller to other system, such as mains supply and windmill generator.
- (2) The controller is intended for indoor use only. Protect it from direct sunlight and place it in a dry environment.
- (3) Batteries generate explosive gases during normal operation. It is important never allow a spark or flame in vicinity of battery.
- (4) Be sure to always keep children away from batteries and acid!
- (5) Do not disassemble the MPPT controller, it does not have any user-serviceable parts.
- (6) The controller warms up during normal operation. Do not touch the heatsink at the bottom of the controller.

Note: It is important that the battery is fully charged frequently (at least monthly). Otherwise the battery will be permanently damaged.

2. MPPT Controller Instructions

2.1 Overview

MPPT-10 solar charge controller is multi-stage Maximum Power Point Tracking (MPPT) photovoltaic battery charge controller with our own technology. It's main topology adopts in Buck conversion circuit, and uses MCU to adjust the solar panels working point intelligently in order to make the solar panels output its maximum power. When the circumstances change, the working point of solar panels deviate from the maximum power point, MCU will adjust the solar panels working point based on MPPT calculation to make the solar panels back to the maximum power point again(refer to Chapter 2.4 about MPPT technology introduction). Compared with PWM controller, MPPT controller can increase the output power of solar panels by 5%~30%. The output power increasing proportion is affected by the factors such as solar panels property, humidity and light intensity. The controller uses wall-mount installing (refer to Chapter 4.1). Connecting terminal makes the wiring area bigger and wiring loss less.

2.2 Structure

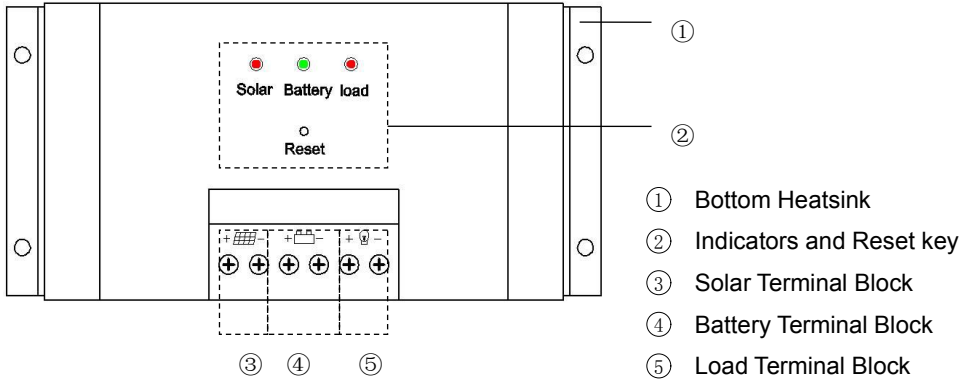

Figure 2-1: Controller Structure Diagram

2.3 Functions

(1) Maximum Power Point Tracking technology

The controller uses Buck conversion circuit and MCU technology to track the maximum power point to implement the maximum output power of solar panels in different illumination intensity and temperature. The MPPT algorithm increases efficiency of your PV system and decreases the quantity of solar panels.

(2) Multi-stage Charge Control

The starting charging voltage of battery is different, the controller will use the different charging strategies to finalize the charging process. When starting charging voltage of battery is lower than 12.4V (for 12V battery), battery will go through three stages as Bulk, Absorption and Float charging. When starting charging voltage of battery is higher than 12.4V (for 12V battery), battery will go through two stages as Bulk and Float charging.

Bulk Charge:

The controller charges the battery by its maximum output current. It is at maximum power point tracking state at this phrase.

Absorption Charge:

The controller begins to limit the charging current to make the battery voltage fixed at a settled absorption voltage (this voltage has temperature compensation) for 2 hours. It increases the charging saturation level of

battery and prevents battery from leaking gas, and this can increase the lifetime of battery.

Float Charge:

The battery is at saturation state, and the controller charges the battery at a trickle current to make the battery voltage fixed at the settled float charging voltage (this voltage has temperature compensation).

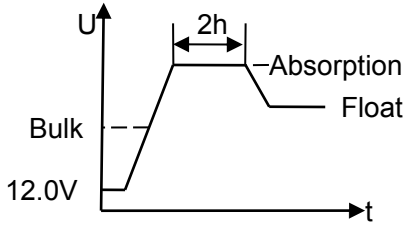

Figure 2-2: Three-stage Charge

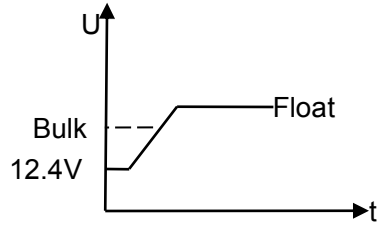

Figure 2-3: Two-stage Charge

(3) Charge Voltage Temperature-compensated

The controller will compensate the Float charging voltage and Absorption charging voltage by $-4\text{mV}/\text{Cell}/^\circ\text{C}$ based on the current battery temperature.

For 12V battery, the compensated voltage $U=(t-25)*6*(-0.004)\text{V}$

For 24V battery, the compensated voltage $U=(t-25)*12*(-0.004)\text{V}$

(4) Discharge Control

The controller monitors the battery voltage all the time. The load will be switched off when the voltage less than the Low Voltage Disconnect (LVD) point, and it won't be switched on until the voltage more than the Low Voltage Reconnect (LVR) point.

(5) Protection against Reverse Connected Battery

Connecting the battery to the controller by reversed polarity (under the circumstances of solar panels disconnected) will not damage the controller.

The controller will work normally after connecting with correct polarity.

(6) Protection against Reverse Connected Solar Modules

Connecting the solar modules with the controller by reserved connection will not damage the controller. The controller will work normally after connecting with correct polarity.

(7) Reverse Current Protection

The controller prevents reverse current from flowing into the solar modules

at night. An additional reverse current diode is not required.

(8) Overtemperature Protection

If the temperature inside the controller becomes too high, then the controller will stop charging to the battery, and it will restart charging the battery again when the temperature decreases to a certain value.

(9) PV Overvoltage Protection

If the input voltage of solar panels exceeds the maximum voltage permitted by the controller, it will enter into protection state automatically and stop charging. When the input voltage recovers to the normal range, the controller will start charging again.

(10) Current-limited for Excessive Charging Current

If the permissible charge current is exceeded, the controller will deviate from the maximum power point to limit the output current to prevent the controller being damaged.

(11) Load Output Overload Protection

If the permissible load current is exceeded, then the load output is switched off. The overload current vs. duration shows as follows:

Rate of Current	Duration (s)
$1.1I_{rate} \leq I < 1.2I_{rate}$	120
$1.2I_{rate} \leq I < 1.5I_{rate}$	60
$1.5I_{rate} \leq I < 1.8I_{rate}$	10
$I \geq 1.8I_{rate}$	0.2
<i>Note: $I_{rate}=10A$, nominal load current</i>	

The controller restarts the load every 3 minutes automatically, but the user can also restart the load by the Restart key.

2.4 MPPT technology Instructions

Solar panels are nonlinear materials, and the output power is mainly affected by illumination intensity, solar panels temperature and load impedance. When the illumination intensity and solar panels temperature are fixed, the output power of solar panels is only affected by load impedance. Different load impedance will make the solar panels work at different point and put out the different power. The following figure will mark the four working points A, B, C, D, and the working point features as follows:

Working point D:

Output voltage is 22.3V, output power is 0W. This point is the open circuit point of solar panels.

Working point C:

Output voltage is 0V, output power is 0W. This point is the short circuit working point of solar panels.

Working point A:

Output voltage is 13V, output power is 74W. This working point is the state when using normal controller, and the solar panels voltage is clamped to 13V by battery.

Working point B:

Output voltage is 17.6V, output power is 92W. This point is the state when using MPPT controller. Because of using power conversion technology, the solar panels voltage is not clamped by battery and still works at maximum power point.

Compare working point A & B, it is easy to find using MPPT controller can increase the using efficiency of solar panels. Compared to normal controller, MPPT controller can generate more power.

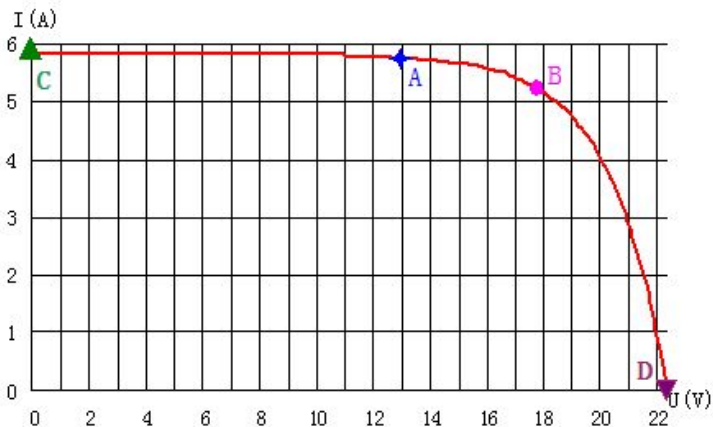

Figure 2-4: Voltage-Current Curve

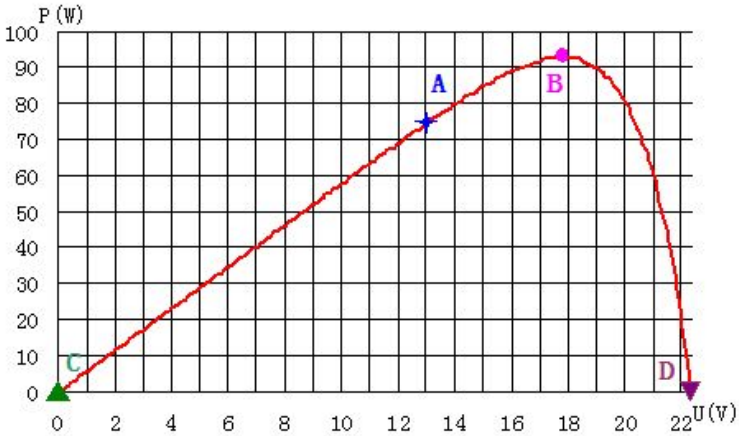

Figure 2-5: Voltage-Power Curve

3. PV System Planning Reference

3.1 System Voltage

The common system voltage of solar system has 3 types: 12V, 24V and 48V. The higher the system voltage, the more power the system can handle. In reality application, user should consider the load power, and the voltage scope permitted by load, and then confirms which system voltage you should use. The power range for each system voltage is as follows:

System Voltage	Recommended Power Range
12V	<800W
24V	<2000W
48V	<6000W

Table 3-1: System voltage vs. Power range

3.2 Solar Modules Configuration

MPPT-10 controller can be connected with Single Crystalline Silicon solar panels and also Thin-film solar panels. When configuring the system, make sure the open circuit voltage of solar panels array is not higher than the maximum voltage permitted by the controller. Table 3-2 introduces the models of Single Crystalline Silicon solar panels and Thin-film solar panels and their parameters. Table 3-3 shows the configuration solution for 12V, 24V and 48V system for solar panels.

Code	Category	Pmax	Voc	Isc	Vpmax	Ipmax
140W-01	Single Crystalline Silicon Module	140W	22.4V	8.33A	17.6V	7.95A
14W-0W-02	Thin-film Module	140W	29.0V	7.12A	23.0V	6.52A
190W-01	Single Crystalline Silicon Module	190W	45.2V	5.65A	36.6V	5.2A
130W-01	Thin-film Module	130W	60.4V	3.41A	46.1V	2.82A

The above parameters are for condition of 25°C, AM1.5 spectrum, and 1000W/m² illumination intensity.

Table 3-2: Solar Panels Model and Parameters

Code	For 12V System	For 24V System	For 48V System
140W-01	N in parallel	two in series, N in parallel	four in series, N in parallel
140W-02	N in parallel	two in series, N in parallel	four in series, N in parallel
190W-01	N in parallel	N in parallel	two in series, N in parallel
130W-01	N in parallel	N in parallel	two in series, N in parallel

N means the quantity number required by the output current.

Table 3-3: Solar Panels Model and System Configuration Solution

3.3 Wire Sizing

The maximum input and output current of MPPT-10 is 10A. To ensure the cable temperature does not exceed the safety range, the copper cable's area must be at least 2.5mm². In reality application, user can choose the appropriate cables according to the system voltage, permitted cable

temperature, cable voltage drop and also cable material. We suggest customer to control the maximum battery voltage loss under 1.5%, and control the maximum voltage loss of solar panels under 2.5%.

The following is the cable length between controller and battery, and the suggested copper cables:

Cable Length	Cable Size in mm ²	Cable Size in AWG	Voltage Loss at 10A (a pair)	Battery Voltage Loss		
				12V	24V	48V
1m	2.5mm ²	#13 AWG	0.14V	1.2%	0.60%	0.30%
2m	4mm ²	#11 AWG	0.18V	1.5%	0.75%	0.38%
4m	6mm ²	#9 AWG	0.24V	2.0%	1.0%	0.50%

Table 3-4: Cable Length & Cable Voltage Drop

The following is the cable length between solar panels and controller, and also the suggested copper cables:

Cable Length	Cable Size in mm ²	Cable Size in AWG	Voltage Loss at 10A (a pair)	Solar Panels Voltage Loss		
				17V	34V	68V
2m	4mm ²	#11 AWG	0.18V	1.1%	0.53%	0.26%
4m	6mm ²	#9 AWG	0.24V	1.4%	0.71%	0.35%
8m	10mm ²	#7 AWG	0.29V	1.7%	0.86%	0.43%

Table 3-5: Cable Length & Cable Voltage Drop

3.4 Over Current Protection

The electrical equipment used in power circuit must be equipped with over current and short-circuit protection devices, and there is no exception for MPPT-10 controller. The controller adopts in the design of common positive pole inside. We suggest users to install over-current breaker or fuse on the negative loop of solar panels input, and also the negative loop of battery output. The capacity of over-current breaker or fuse is 1.25 times of the rated current.

3.5 Lightning Protection

It is the same as other electrical devices that MPPT-20 controller will be damaged by lightning. The controller has limited surge absorption capacity. We strongly suggest users to install lightning surge absorption devices to increase the reliability of the system.

3.6 Grounding

Use 4 mm² yellow and green cable to connect any of the positive terminal of the controller to the ground bus of the system. This can decrease the electromagnetic interference in a certain value.

3.7 System Expansion

If you want to deploy a bigger system, you can expand the system by paralleling several sets of the same controller. More controllers can share with one battery group, but each controller must be connected with the independent solar panels array and the independent load. (Please contact the local distributor for further information.)

4. Installation



1. Protect the controller from direct sunlight or other source of heat.
 2. Place the controller in a dry environment.
 3. A free space of at least 15cm on all side of the controller must be provided.
 4. Mount the controller as close as possible to the batteries.
-

4.1 Dimensions

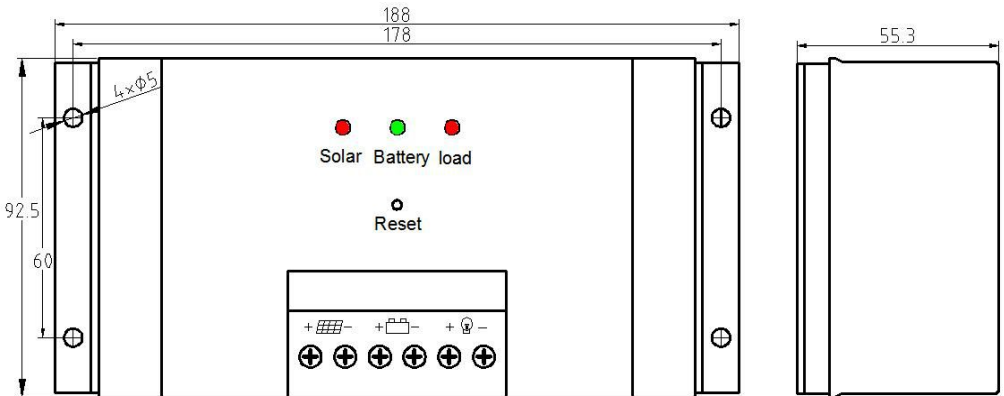

Figure 4-1: Dimensions (Unit: mm)

Mounting hole pitch: 60mm*178mm

Mounting hole diameter: $\Phi 5\text{mm}$

Height*Width*Thickness: 92.5mm*188mm*55.3mm

Connecting terminals: Maximum 6mm²

4.2 Connecting Diagram

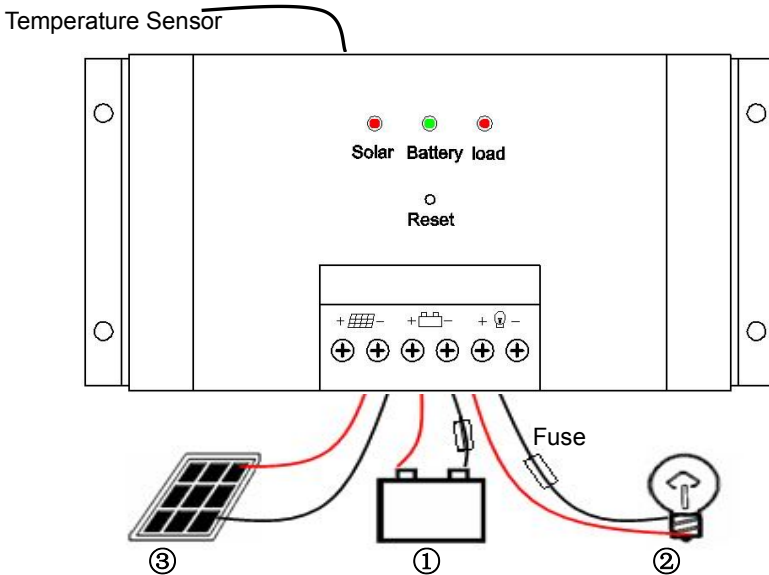

Figure 4-2: Connecting Diagram

4.3 Wiring

- A. Choose the appropriate cables requested as Chapter 3. Prepare 4 sets of M5 screws (used to fix the controller on the wall or other vertical plane).
- B. Prepare cutting pliers, cross screwdriver and multi-meter, etc.

4.4 Installation Process



Note: Please switch off the breakers of battery, solar panels array before installing the controller. Do not touch the positive and negative pole of solar panels or battery at the same time when installing, otherwise you have the risk of electrical shock.







- A. Mount the controller on the wall and fasten the screws.
- B. Check whether the battery voltage and solar panels array voltage is within the requested range.
- C. Switch off the over-current breaker or fuse of the battery, solar panels array and load.
- D. Wiring.
 - (1) Connect the battery with the battery terminal on the controller by cables and fasten the screws.
 - (2) Connect the load with the load terminal on the controller by cables and fasten the screws.
 - (3) Connect the solar panels array with the solar panel terminal on controller by cables and fasten the screws.
- E. Switch on the breaker or fuse of the battery, then the 3 indicators indicate the system status. Switch on the breaker or fuse of the load. (more information about the indicators see Chapter 5.2 and 5.3)
- F. Switch on the breaker or fuse of the battery, then the controller starts to charge the battery.

5. Operation Instructions

5.1 Button Function

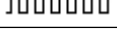
There is only one concealed button on the controller, which used to restart the load when the controller is in overload protection state. The second function of the button is to control the load. Press the button and hold about 3 seconds, then the load will be switched off. This can also switch on the load.

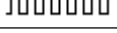
5.2 LED Displays

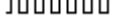
LED	Meaning	Status
Solar (Red)	PV Voltage Low	off
	MPPT Charge	illuminates
	Absorption Charge	 T=2s
	Float Charge	 T=1s
	PV Overvoltage Protection	 T=0.5s
Battery (Green)	Battery Disconnect	off
	Normal Operation	illuminates
	Undervoltage Protection	 T=2s
	Overvoltage Protection	 T=1s
	Overtemperature Protection	 T=0.5s
Load (Red)	Load Off	off
	Load On	illuminates
	Heatsink Temperature Sensor Error	 T=2.2s
	Overload Protection	 T=1s
	Load Short-circuit Protection	 T=0.5s

5.3 System Voltage Indication

The MPPT-10 controller adjusts itself to 12V or 24V system voltage automatically. The system type indicates by the green led when the controller startup every time. Details show as follows:



Figure 5-3: System Voltage Indication Diagram

6. Faults and Remedies

6.1 Protection Remedies

Fault	Phenomenon	Cause / Remedy
Battery voltage too low	Load off Charging on	Check the battery voltage and manually recharge the battery if necessary. Loads directly connected to the battery can cause deep discharge.
Battery voltage too high	Load off Charging off	Check installation. Check the battery voltage and check any additional charging sources if present.
PV voltage too high	Load on Charging off	Check the PV system configuration. The PV open circuit voltage increases while the ambient temperature decreases.
Excessive load current	Load off Charging on	Reduce the load current at the load output. The load may cause current peaks.
Load output short circuit	Load off Charging on	Rectify short circuit. Disconnect and reconnect the load.
Controller inside temperature too high	Load on Charging off	Allow the controller to cool down. Check for possible causes of overheating (mounting location, other heat sources). Possibly reduce the charge current. Make sure the controller is adequately ventilated.
Inside temperature sensor error	Load on Charging on	Disconnect the load, solar modules and battery. Re-install the controller. If the error recurs, then please contact your specialist dealer.
Self-test error	Load, charging indefinite	Disconnect the load, solar modules and battery. Re-install the controller. If the error recurs, then please contact your specialist dealer.

6.2 Common Faults and Remedies

Phenomenon	Cause	Remedy
LEDs no indication	The battery is connected to the controller with the wrong polarity. The fuse burns out.	Check the fuse. Disconnect the battery and reconnect it to the controller with the correct polarity.
Battery overvoltage protection when startup	The controller adjusts to the wrong system voltage.	Disconnect the load, solar modules and battery. Waiting for about 10 seconds and then re-install the controller.
Stay in direct charging mode	The PV MPP voltage too low.	It's normal. If possible you can re-configure the PV system to enlarge the PV open circuit voltage.

7. Technical Data

Model		MPPT-10
Input	Maximum PV voltage	≤70V
	MPPT voltage range	12V~70V (12V) 24V~70V (24V)
Output	System voltage	12V (24V)
	Maximum battery voltage	16V (32V)
	Maximum charging current	10A
	Maximum load current	10A
	Own consumption	≤15mA
	Charging control mode	3-stage (Bulk, Absorption, Float)
	Float charge	13.8V (27.6V)
	Absorption charge	14.4V (28.8V), for 2 hours
	Load disconnection (LVD)	11.5V (23.0V)
	Load reconnection (LVR)	12.6V (25.2V)
	Temperature compensation	-4mV/ cell/ °C
	Battery type	Lead acid (GEL, AGM, Flooded)
Other	Maximum efficiency	97%
	Human interface	LEDs, button
	Cooling style	Passive cooling
	Maximum wire size	6 mm ²
	Ambient temperature range	-10 to +50 °C
	Storage temperature range	-30 to +80 °C
	Humidity	0 to 90%, no condensation
	Dimensions	92.5 x 188 x 55.3 mm
	Weight	0.46 Kg
	Grounding	Positive grounding
	Degree of protection	IP32

Note: Technical data at 25 °C / 77 °F