

401H000418

# 712 Rework System

## 2 IN 1

### Instruction Manual

Thank you for purchasing the rework system. It is designed for lead free soldering. Please read this manual before operating the unit. Store this manual in a safe, easily accessible place for future reference.

## TABLE CONTENT

1. Summary.....	1
2. Precaution.....	1
3. Soldering Iron Part.....	2
3.1 Safety Instruction of the soldering part.....	2
3.2 Specification and characteristic of the soldering part.....	2
3.2.1 Specification.....	2
3.2.2 Characteristic.....	3
3.3 Operation instruction.....	4
3.3.1 Prepare.....	4
3.3.2 Setting the parameters.....	4
3.4 Use / care and maintenance.....	9
3.4.1 Select a correct tip.....	9
3.4.2 Maintenance about the tip .....	9
3.5 Error messages.....	11
3.6 Calibrating the Temperature.....	12
3.7 Check and Replace the Soldering Iron.....	12
3.7.1 Check the soldering iron.....	12
3.7.2 Checking the heating element.....	14
3.7.3 After Replace the heating element.....	14
3.7.4 Test the heating element.....	14
3.8 Tips.....	15
4. SMD Re-soldering.....	16
4.1 Safety Instruction.....	16

4.2 Specifications and Characteristics.....	16
4.2.1 Specification.....	16
4.2.2 Characteristics.....	16
4.3 Usage.....	17
4.4 Operation Instruction.....	17
4.4.1 Key instruction.....	17
4.4.2 Operation.....	17
4.5 Parameters setting.....	18
4.5.1 The sound setting.....	18
4.5.2 Setting of the Temperature and the Airflow.....	19
4.5.3 Password setting.....	20
4.6 Sleeping.....	21
4.6.1 How into the Sleeping State.....	21
4.6.2 Resume.....	21
4.7 Message Instruction.....	22
4.8 Calibrating the Temperature of Airflow.....	22
4.9 Replacing the Parts.....	23
4.9.1 Assembly and change of the nozzle.....	23
4.9.2 Replacing the Heating Element.....	23

- Reassemble the handle according to the opposite order of disassembling. The heating part of the heater element must be inserted into the end. The sensor cord has polarity and it must connect with the same color.

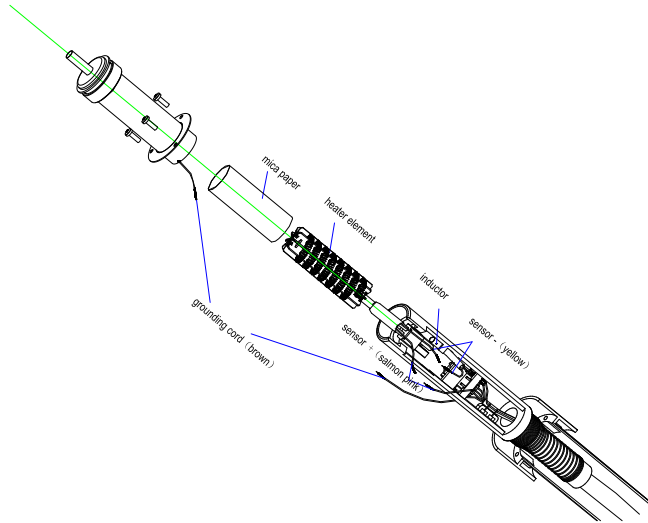

 Note: Avoid invalidate the ground cord when replacing the heater element.

## 1. Summary

The unit includes the soldering part and de-soldering part. It is a good assistant. The two tools can work together.

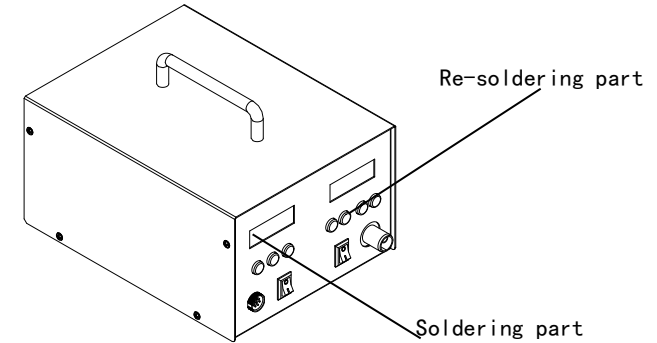

Note: “△” and “▽” mean the temperature adjusting keys of the soldering part.  
 “TEMP▲” and “TEMP▼” mean the temperature adjusting keys of the de-soldering part.  
 “AIR ▲” and “AIR▼ ” mean the airflow adjusting keys.

## 2. Precaution

- Please use the unit only as the described manner, and avoid abusing it.
- The unit shall only be used with rated voltage and frequency. (Refer to the trademark back of the equipment.)
- Do not use the unit near the flammable items.
- The unit is equipped with a 3-wires grounding plug and must be plugged into a 3-terminal grounded socket. Do not modify plug or use an ungrounded power socket. If an extension cord is necessary, use only a 3-wire extended grounding cord.
- A periodically maintenance (description see in this manual) of the unit is necessary. Do not use the unit if it is damaged, especially the power supply cord and the case.

- Do not modify the unit by oneself.
- Replace only with genuine parts.
- Children do not recognize the risks of the electrical appliance. Therefore use and keep the unit out of the reach from children.

### 3. Soldering Iron Part

#### 3.1 Safety Instruction of the soldering part

When the power is on, the tip temperature is very high. Mishandling may lead to burns or fire, be sure to comply with the following precautions:

- Do not touch the metallic parts near the tip.
- Advise other people in the working area to turn the power off when in a break or after using the equipment because the unit can reach a very high temperature and may cause potentially dangerous.
- No replace any parts or install the tips before turning the power off and cooling down the searing-iron to room temperature.
- Do not use the iron for the other applications except soldering.
- Do not rap the soldering iron against the workbench to shake off residual solder, otherwise the iron will be damaged by shocks.
- Do not wet the soldering station. Don't use or disconnect it with wet hands, and without to force the supply cord.
- The soldering process will produce smoke, so make sure the area is well ventilated.

#### 3.2 Specification and characteristic of the soldering part

##### 3.2.1 Specification

6. If the temperature still has some departure, you can repeat calibration according with the above steps.

*Note: Suggest using 191 or 192 thermometer to measure the temperature.*

### 4.9 Replacing the Parts

#### 4.9.1 Assembly and change of the nozzle

1. **Assembly:** Select one befitting nozzle and insert it into the outlet's steel pipe. Press it with hand until the nozzle has been locked. It can be used after the nozzle has been fixed reliably.
2. **Change:** Take the handle down from the holder after the nozzle has cool down. There is a slot between the nozzle and the outlet's steel pipe. By the slot, put the handle on the disassembly plate of the nozzle that is fixed at the holder. After that, fix the holder with one hand and pull out the nozzle. Change another nozzle.

*Note: The nozzle can be ordered by the custom. Change the nozzle after it has cool down.*

#### 4.9.2 Replacing the Heating Element

1. Replace the heating element after the handle has cooled down.
2. Screw down the fixation screws in handle and then take off the handle cover.
3. As shown in the diagram, move back the spring in the handle module and take out the steel tube.
4. Cut off the strap, disconnect the sensor cord and the connector, ground cord and ground socket. And then take out the steel tube and the broke heater element.
5. Wrap the mica on the new heater element and insert into the steel tube. It is better to right insert into the steel tube and cut off the unwanted mica.

 *Note: The sensor cords of heater element putting on the red and yellow hot shrinking tubes are on the opposite part of the ground cord.*

## 4.7 Message Instruction

1. **“H-E” Heater error:** If there is some malfunction in the heater or in the heater circuit, the temperature parameter of LCD will display **“H-E”**. It must test the heater and the correlative parts.
2. **“S-E” Sensor error:** If there is some malfunction in the sensor or in the sensor circuit, the temperature parameter of LCD will display **“S-E”** and the power supply to the handle will be cut off.
3. **ERR:** If there is some malfunction in the fan or in the fan circuit, the LCD will display **“ERR”** and it must test the fan and the correlative parts.
4. During the work, the displaying temperature is less 50 °C and not heat up, it means the heater element has been broke and needs to change a new one.

## 4.8 Calibrating the Temperature of Airflow

1. It is better to calibrate the temperature after changing the heater element of the SMD rework handle. The method of calibrating the temperature is as following:
2. In work state, set the calibration temperature 300°C.  
When the temperature is stable and the window displays “Real Temp”, test the outlet temperature of the handle with thermometer and write down it.
3. **Into the calibration mode:** When the temperature is stable, press the keys “TEMP▲” and “AIR▲” keys at the same time about 15seconds, and then the LCD will display “CAL” about two seconds and the system will enter into the temperature calibrating mode. Input the testing temperature after the hundreds digit twinkling.
4. Press “TEMP▲” or “TEMP▼” key to setting the data and press “AIR▲” or “AIR▼” key to move the cursor. After inputting the testing result, click the “AIR▲” or “AIR▼” key.
5. If calibration is successful, the LCD displays “SAV---”, if not successful, the LCD displays “no---”.

Power	90W
The temperature range of the iron	50°C~500°C/200°C~450°C
The temperature range of the sleeping	50°C~250°C
The time range of the sleeping	0~250 (unit: minute)
The time range of the shutting	0~250 (unit: minute)
Temperature Stability	±2°C (Without air flow and no load)
Highest Ambient Temperature	40°C
Tip to Ground Resistance	<2Ω
Tip to Ground Potential	<2mV
Heating Element	Electromagnetic heater
Handle Power Cord	1.2m

### 3.2.2 Characteristic

1. The thermocouple sensor locates on the top of tip. Recovery of the temperature and calefactive is rapid and exactly. Display the temperature with the large LCD by microcomputer and Control the temperature by PID. Especially it is suitable to the lead free soldering.
2. The switch power supplies the power supply and protects the short circuit, over temperature and over voltage and reduces the loss of the copper and the iron. Besides, the output power is stable and not fluctuating with the voltage fluctuating.
3. Lock the calibration and the parameter setting with the password.
4. Set the parameters by keys. Sleep or turn off automatically at the setting time.
5. The up and down limited temperature can be set according to the demands. If the temperature exceeds the setting limit value, the soldering station sounds alarm.
6. Digital calibration and operate conveniently and easy.
7. Various types of tips are available and replace tips conveniently.
8. The soldering handle is light and use is comfortable.

## 3.3 Operation Instruction

*Note: please check the power supply is according to the rating voltage on the nameplate of the device before operation.*

### 3.3.1 Prepare

#### 1. Iron Holder and Sponge

- (1) Dampen the small cleaning sponge with water and then squeeze it dry. Place it in the groove of the iron holder base.
- (2) Add a little water to the iron holder. The small sponge will absorb the water to keep the large sponge above it wet all times. It may only use big sponge and not use small one.
- (3) Dampen the larger cleaning sponge and place it on the iron holder base.

 *Note: If the sponge becomes dry during working, add appropriate water.*

#### 2. Connection

- (1) Connect the connector plug of the iron handle cord to the socket in front of the soldering station. Take notice of the inserting position of connector plug.
- (2) Place the soldering iron in the iron holder.
- (3) Insert the power plug into the grounding power socket.
- (4) Connect one end of grounding cord to the grounding hole of the soldering station and the other to ground.
- (5) Switch on the power supply.

### 3.3.2 Setting the parameters

#### 3.3.2.1 Setting the password

*Note: The initial password is 000 and the temperature can be set after turning on the power supply at this state. If administrator wants to limit the authority and he can change the password and then those being authorized can set the parameters.*

##### 1. Input the password

- (3) **If the password is correct:** the display shows “SET” about 20 seconds.
  - ① **During the 20s of displaying “SET”:** click “AIR▲” or “AIR▼” key

into the password setting (refer to the password setting at the initial state).

- ② **During the 20s of displaying “SET”:** click “TEMP▲” or “TEMP▼” key to exit the password setting and come to the work state.
- ③ **If don't do any operation during the 20s of displaying “SET”:**

The system comes into the work state.

3. After setting new password and turn on the power switch, the display will show “no” and then comes into the work state or sleep state.

*Note:*

*After setting a new password in the initial state, it must turn off the power switch and then turn on it, and then the locking function of the parameter setting comes to run. Or else, it can change the parameter after changing the password.*

## 4.6 Sleeping

### 4.6.1 How into the Sleeping State

1. Put the handle on the handle holder, the system will to the sleeping state come automatically.
2. During the system from work state to sleeping state, the window will display “Off”. And then when the temperature cooling down to 100 °C, the unit comes into the sleeping state. In the sleeping state, the LCD will display “Sleep”.

### 4.6.2 Resume

1. When the handle of the rework station is putting on the handle, it cannot be resumed from sleeping.
2. Take down the handle from the holder. At the time, the unit will work at once.

## 4.5.3 Password setting

1. In the initial state (the password is 000) and the password setting steps as followings:



Turn off the power switch firstly, and then press the key “AIR▲” or “AIR▼” and turn on the power switch. Not loosely the “AIR” key until the window displays “C”. After that, the window displays “password” and “SET”, which means the system comes **into the password setting state**.

- (1) In the password setting interface first time, the cursor of hundred twinkles. Press “TEMP” and “AIR” keys to set the password.
    - ① Press “TEMP▲” or “TEMP▼” key to select password data from 0~9.
    - ② Press “AIR▲” or “AIR▼” key to move the cursor among the hundreds, tens, one-digit.
  - (2) Finishing the first password input, click key “AIR▲” or “AIR▼” into the secondary password input, and hundreds digit twinkles.
  - (3) If the two passwords are not identical, the setting of password is not successful and the window displays “no”. After that, the system comes into work state and the password is still the former one.
  - (4) If the next password is identical with the former one, the setting of password is successful and the unit displays “SAV\_\_\_” and has sound (run sound function). After that, the system comes into work state.
2. If the password is not the initial password 000, it must input the correct password before into the password setting interface.
    - (1) **Input the password:** Turn off the power switch firstly, and then press the key “AIR▲” or “AIR▼” and turn on the power switch. Not loosely the “AIR” key until the window displays “C”. After that, the window displays “password” and the cursor of hundred twinkles. Which means the system comes **into the password-inputting interface**.
    - (2) **If the password is not correct:** the display shows “no” and then comes into the work state.

- **Enter the password setting:**

Turn off the power supply. press and hold “△” and “▽” keys simultaneously and then press the power switch until the display shows . It means in the password setting state.

- **Enter the initial password:**

Press “\*” key after the display shows , and then the display shows . In the  state, input the initial password by pressing “△” and “▽” keys. And then press “\*” key after inputting the right password.

- **If the inputted password is error:**





The soldering process will jump over the password setting process into the normal working process after the display shows the setting password about four seconds. But the temperature cannot be changed in normal working process because of inputting the error password.

- **If the inputted password is correct:**

If the display shows , this means the inputting password is correct. After displaying about four seconds, the station will come into the normal work process, and it can set the temperature.

## 2. Input the new password

*Note: the next inputted password must be same with the last inputted password, and then the new password will be recorded in the soldering station and change the password successfully. (Operation as follows)*

- (1) **Input the new password:** when inputting the correct initial password, the display shows  and then press “\*” and “▽” keys simultaneously in about four seconds then showing . It is in the new password setting process. Press “\*” key and the display shows . After that, press “△” or “▽” key to input the new password.
- (2) **Repeat the new password:** after inputting the new password and then press “\*” key to . Now it must input the new password again. Press “\*” key and the display shows . After that, press “△” or “▽” key to input the new password.



**(3) If the next inputted password is same with the last inputted password:**  
 press “\*” key and then the new password will be recorded in the soldering station and change the password successfully.

**(4) If the next inputted password is not same with the last time:**  
 Press “\*” key to  and then input the new password again until the lately two passwords are identical.

### 3. Setting the temperature

Note:

- Make sure the temperature of the station can be adjusted (inputted password is correct or the password is initial 000).
- Do not turn off the power supply when setting the temperature, or else the setting value will not be memorized.

#### (1) Into temperature setting

If the password is 000, it can jump into the temperature setting when turning on the power supply.

If the password has been changed, it must input the correct password firstly and then the process can come into the temperature setting.



#### (2) Temperature setting

**Temperature up:** Don't press “\*” key, and press “Δ” key directly. And the “Set Temp” will raise 1 °C and the display will show the setting temperature. If pressing the “Δ” key about one second, the setting temperature will rise rapidly. And then loose the “Δ” key till the needed temperature.

**Temperature down:** Press “∇” key directly. And the “Set Temp” temperature will drop 1 °C and the display will show the setting temperature. If pressing the “∇” key about one second, the setting temperature will drop rapidly. And then loose the “∇” key till the needed temperature.

1. Press the TEMP “▲” and “▼” about three seconds at the same time in the working state or in the sleeping state. It can switch on or off the sound.
2. When the LCD displays “🔊”, the system has key sound and alarm sound. When not displaying “🔊”, the system hasn't key sound and alarm sound.

### 4.5.2 Setting of the Temperature and the Airflow

#### 4.5.2.1 Temperature Setting

**Raise temperature:** Click “TEMP ▲” key and then the temperature will rise 1 °C, and the LCD displays the current setting temperature. If pressing “TEMP ▲” not loosely at least one second, the setting temperature will rise rapidly. Loose the “TEMP ▲” key until up to the needed temperature.

**Reduce temperature:** Click “TEMP ▼” key and then the temperature will drop 1 °C, and the LCD displays the current setting temperature. If pressing “TEMP ▼” key not loosely at least one second, the setting temperature will drop rapidly. Loose the “TEMP ▼” key until down to the needed temperature.

#### 4.5.2.2 Airflow Setting

**Raise Airflow:** Click “AIR ▲” key and then the airflow grade will rise 1, and the LCD displays the current setting airflow grade. If pressing “AIR ▲” not loosely at least one second, the setting airflow grade will rise rapidly. Loose the “AIR ▲” key until up to the needed airflow grade.

**Reduce Airflow:** Click “AIR ▼” key and then the airflow grade will drop 1, and the LCD displays the current setting airflow grade. If pressing “AIR ▼” not loosely at least one second, the setting airflow grade will drop rapidly. Loose the “AIR ▼” key until down to the needed airflow grade.

1. Select suitable nozzle to install. After that, put the re-soldering handle on the holder.
2. Insert the power plug into the power socket and then switch on the “POWER” key.
3. Take down the re-soldering handle from the holder and the system comes into the work state. When the temperature is stable, the temperature window displays “Real Temp”.
4. If **in the unlocking state**, it can set the temperature and the airflow. Click “TEMP▲” or “TEMP▼” key to set the temperature and click “AIR ▲” or “AIR ▼” key to set the airflow (refer to the “Setting of the Temperature and the Airflow”).
5. If **in the locking state**, it cannot set the temperature and the airflow and after getting the power supply, the display shows “no” before into working.
6. After working, put back the handle on the holder. After that, the unit comes into the cooling state and when cooling down to 100°C, the unit comes into sleeping state.
7. If not use in a period of time, it must turn off the power switch and cut off power supply.

**⚠Caution:**

- The initial password is “000”. At the initial state, the system is in the unlocking state and it can set the parameters.
- For prolong the life of the heater and protect the safety of the chip, use as low temperature as possible and as big airflow as possible if it can finish the de-soldering work.

## 4.5 Parameters setting

Note: In the password locking state, the sound, temperature and the airflow cannot be set.

### 4.5.1 The sound setting

### 4. Mode setting

When inputting the correct password and the display shows , press “△” and “\*” keys simultaneously to the mode setting. The display shows the current setting value and change the type of the modes by pressing “△” and “▽” keys. The changing series as following:

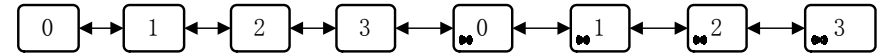

Working mode table

Working mode	Temperature range	Tip type	Alarm	Remark
0	200°C~450°C	Normal tip	No	((○)) is a alarming mark.
1	200°C~450°C	Big tip	No	
2	50°C~500°C	Normal tip	No	
3	50°C~500°C	Big tip	No	
((○)) 0	200°C~450°C	Normal tip	Yes	
((○)) 1	200°C~450°C	Big tip	Yes	
((○)) 2	50°C~500°C	Normal tip	Yes	
((○)) 3	50°C~500°C	Big tip	Yes	

## 5. Sleep time setting

The station has an auto-sleep function. When not operating the station during a certain period of time (the setting sleep time), the power supply will be cut off and the station will come into the sleep state.

- 1) Select the needing mode and then press “\*” key to the process of “sleep time” setting. The display shows  and then press “△” or “▽” key to change the sleeping time. The range of sleeping time is from 0 minute to 250 minutes.
- 2) After finishing setting the sleeping time, press “\*” key to the process of off time setting.
- 3) To resume soldering, there are several ways as follows:
  - \* Turn the power switch off and then turn on.
  - \* Press any key of the soldering part.
  - \* Take up the iron- handle.

Note: The soldering iron must be placed at the soldering iron station. And only in

*this state, the soldering station can sleep automatically when up to the setting time.*

## 6. Off time setting

**If the system isn't resumed during the sleeping time, the power supply will be shut off automatically, and the soldering part will stop working. Turn on the power switch to resume working.**

- 1) The process of setting "off time" is after the process of setting "sleep time". At the "off time" status, the display shows 050 and then press "▲" or "▼" key to change the off time.
- 2) The range of sleeping time is from 0 minute to 250 minutes.

*Note: The off time should be longer than the sleep time, otherwise, the soldering station part will be turned off immediately after it comes into sleep state.*

## 7. Sleeping temperature setting

- 1) In the process of "sleeping temperature" setting, the display shows "sleep" and "set temp", and then press "▲" or "▼" key to change the sleeping temperature.
- 2) The range of sleeping temperature is from 50°C to 250°C.

## 8. Up Temp setting

- 1) In the up temp setting state, the display shows "050" and press "▲" or "▼" key to change the temperature. Once difference in temperature between the real temperature (Real Temp) and the setting temperature (Set Temp) is bigger than the Up Temp, the soldering station part will alarm when in the alarming mode.
- 2) The range of the "Up Temp" setting is from 0°C to 99°C.

## 9. Down Temp setting

- 1) In the up temp setting state, the display shows "050" and press "▲" or "▼" key to change the temperature. Once difference in temperature between the real temperature (Real Temp) and the setting temperature (Set Temp) is bigger than
3. Closed loop sensor, temperature can be controlled by zero voltage triggering mode. Large power and rapid heating. Temperature can be conveniently

adjusted and the temperature is accurate and stable, and not affected by airflow.

4. It is with a brushless whirlpool motor and the airflow is adjustable with a wide range but no level. It is a multipurpose unit.
5. Automatic cooling system can prolong the heating element's life and protect the handle.

## 4.3 Usage

1. It is suitable to the de-soldering of the SMD components, such as SOIC, CHIP, QFP, PLCC, BGA and so on.
2. It is suitable to hot shrink, drying, remove lacquer and mucosity, thaw, preheating, disinfect and so on.
3. It is suitable for the situation needing different range airflow, softer or heavier.

## 4.4 Operation instruction

### 4.4.1 Key instruction

POWER key	Power supply switch of the re-soldering part
TEMP▲/▼ key	Adjust the temperature of the hot air
Press TEMP▲/▼ keys at one time	Click it and work in the CH2 channel
AIR ▲/▼	Adjust the airflow or Make sure the setting function

### 4.4.2 Operation

*Note: Check the parts in the package as the packing list. Some option parts may be not in the package if do not order.*

## 4. SMD Re-soldering

### 4.1 Safety Instruction

1. The air outlet and its surrounding area maybe very hot. Please take great care and not to be burned.
2. Do not put the handle on the workbench or other places instead of the holder when not in using.
3. Please keep the air outlet clear and not be blocked.
4. After work, the handle must be placed on the holder and never place the handle on the workbench or other places. The unit can be turned off only after it cools below 100°C (sleeping mode) automatically.
5. Keep the air outlet at least 2mm from the object. Select the appropriate nozzle according to demands. Differences in temperature may exist when different nozzle is used.

### 4.2 Specifications and Characteristics

#### 4.2.1 Specifications

Power	1000W
Voltage	200V~240V 50HZ/60HZ
Temperature range	100°C~500°C
Airflow range	1~120
Maximal airflow	200l/min

#### 4.2.2 Characteristics

1. There is lock-function and the parameter setting with password protection.
2. Rea-time operation and automatically sleeping function when putting the handle on the holder. And it can set parameters in the sleeping state.

the Down Temp, the soldering station part will alarm when in the alarming mode.

- 2) The range of the “Down Temp” setting is from 0°C to 99°C.

### 3.4 Use / care and maintenance

#### 3.4.1 Select a correct tip

1. Select a tip which maximizes contacting area between the tip and solder joint. Maximizing contact area transfers the heat more efficient, helping the operators to produce high quality solder joints quickly.
2. Select a tip with transferring the heat to the solder joint well. A tip with shorter length can control more precise. And the Longer or angled tip may be needed for soldering densely populated boards.

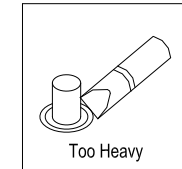
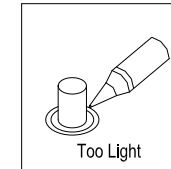
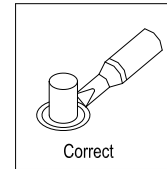

#### 3.4.2 Maintenance about the tip

##### 3.4.2.1 Tip's using caution

1. High soldering temperature can degrade the function of the tip and use the tip with the lowest possible soldering temperature. The excellent thermal recovery characteristics ensure efficient and effective soldering event at low temperatures. This also can protect the sensitive components from thermal damage.
2. When using the soldering iron continuously, be sure to loosen the tip and remove all oxides on the tip at least once a week. This helps prevent reducing of the tip temperature.

3. Never keep the soldering iron at high temperature for a long time when not using. Because the tip will be covered with oxide that can greatly reduce the tip's heat conductivity.
4. Wipe the tip and coat it with fresh solder after using. This helps to prevent tip oxidation.
5. Clean the tip regularly with a cleaning sponge. Oxides and carbides deriving from the solder and the flux can form impurities on the tip. These impurities can result in defective joints or reduce the heating conductivity of the tip.
6. Use fine tips only when necessary. The plating on fine tips is less durable than the plating of the blunter tips.
7. Do not use the tip as a detecting tool. Bending the tip can cause the plating to crack and shorten the tip's life.
8. Use the minimum activation flux necessary to do the job. Higher activation flux is more corrosive to the tip plating.
9. Don't apply pressure to the tip. More pressure does not equal more heat. To improve heat transfer, use solder to form a thermal bridge between the tip and the solder joint.

### 3.4.2.2 Check and clean the tip

1. Set the temperature to 250°C.
2. When the temperature stabilizes, clean the tip with the cleaning sponge and check the condition of the tip.
3. If there is black oxide on the solder-plated portion of the tip, coat new solder (containing flux) and then wipe the tip on the cleaning sponge. Repeat until the oxide is completely removed and then coat with the new solder.
4. If the tip is deformed or heavily eroded, replace it with a new one.

### 3.4.2.3 Re-new a de-tinned tip

1. Why does a de-tinned tip fail to work?

A de-tinned tip is one not wetted with solder. This exposes the plating to oxidation and degrades the heat transfer efficiency of the tip.

## 3.8 Tips

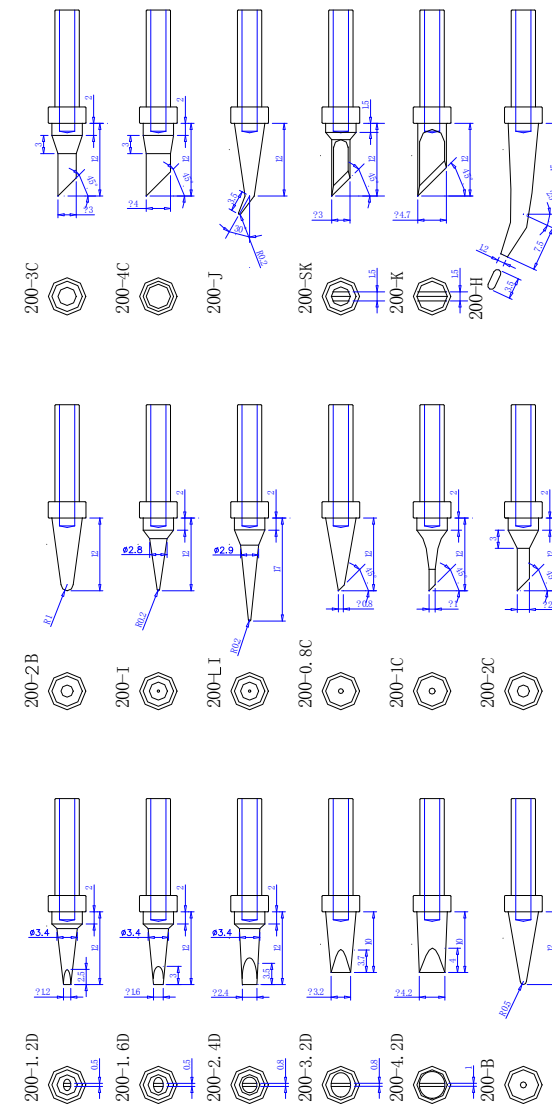

### 3.7.2 Checking the heating element

Measure the heating element when it comes back to room temperature:

1. Resistance value of heating element (White and Black wire) under  $4\ \Omega$ .
2. Resistance value of sensor (Red and Grounding wire) under  $10\ \Omega$ .
3. If the resistance value isn't normal, replace the heating element.

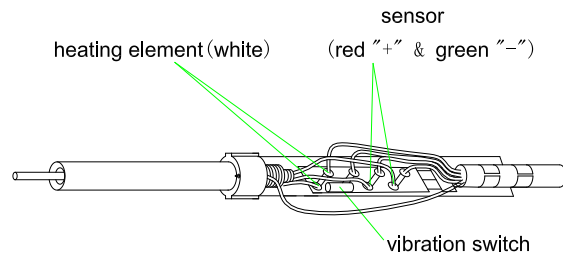

### 3.7.3 After replace the heating element

After replacing the heating element.

1. Measure the resistance value between ①pins 4 & 1 or 2, ②pins 5 & 1 or 2, ③ pins 6 & 1 or 2, ④pins 6 & 4 or 5. If it is not  $\infty$ , the heating element and sensor are touching. This will damage the P.W.B.
2. Measure the resistance value "a", "b" and "c" to confirm that the leads are not twisted and that the grounding wire is properly connected.
3. To confirm that the clasp (9) is clasped with heating element (10).

### 3.7.4 Replace the fuse

4. Turn off the power switch.
5. And then pull out the fuse plug in the power plug.
6. Open the fuse cover board and take out the broken fuse. Replace a new fuse.
7. And then put back the fuse cover board in place.

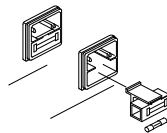

### 2. Detinning is caused by:

- (1) Failure to keep the tip coating with fresh solder while not in using.
- (2) High temperatures.
- (3) Insufficient melting in soldering operations.
- (4) Wiping the tip on dirty or dry sponges or rags. (It should use a clean, wet, industrial grade, sulfur-free sponge.)
- (5) There are impurities in the solder, iron plating, or on the surfaces to be soldered.

### 3. Renew a de-tinned tip

- (1) Remove the tip from the handle after the tip cooling down.
- (2) Remove the dirty and oxides from the tip with 80-grit abrasive polyurethane foam stock or a 100-grit emery.
- (3) Wrap the stannum including rosin ( $\phi\ 0.8\text{mm}$  or larger) around the newly exposed iron surface, insert the tip into the handle, and turn on the power switch.

### ⚠Note:

- Never file the tip to remove oxide.
- Proper daily care can prevent the tip from de-tinned.

## 3.5 Error messages

Various error messages will be displayed when there is something wrong with the soldering part.

**S - E**

**Sensor error:** If there is some malfunction in the sensor or anywhere in the sensor circuit, "S-E" will be displayed and the power supply to the soldering iron will be cut off.

**H - E**

**Heater error:** If there is something wrong with the heating element, "H-E" will be displayed and the power supply to the soldering iron will be cut off.

### 3.6 Calibrating the Temperature

1. The soldering iron should be recalibrated every time after replacing the iron, the heating element or the tip.
2. It adopts digital calibration mode and input the revision value by pressing key.
3. Methods of recalibrating the temperature:
  - (1) Set the temperature of the soldering station to a certain value.
  - (2) When the temperature stabilizes, measure the tip's temperature with thermometer and write down the values.
  - (3) Press “\*” key unlooseningly and then press the “△” and “▽” keys simultaneously, the soldering station enters the temperature calibration mode and LCD displays “Cal Temp”.
  - (4) The number is not flash and press “△” or “▽” key to record the temperature tested by the thermometer to the soldering station. After that, press “\*” key and the process of temperature calibration is end.
  - (5) If the temperature still has some departure, you can repeat calibration in according with the above steps.

*Note: \* Suggest using the 191 or 192 thermometer to measure the tip's temperature.*

*\* If the soldering station part is locked by the password, it will not be able to calibrate the tip temperature and you must input the correct password.*

### 3.7 Check and replace the part of soldering iron

When there is something wrong with soldering iron, you can check and test it. If it is broken, replace the broken element.

#### 3.7.1 Check the soldering iron

Pull out the plug and measure the resistance value between the pins of the connecting plug when the heating element cooling down to the room temperature.

- (1) If the values of ‘a’ and ‘b’ are different from the values in the following table, replace the heating element or sensor or cord assembly. Refer to the following steps.
- (2) If the value of ‘c’ is over the below value, remove lightly the oxidation in the joint part of the tip and the heat element with sandpaper or steel wool.

a.	Between pins 4&5 (Heating Element)	Under 4 Ω (Normal)
b.	Between pins 1&2 (Sensor)	Under 10 Ω (Normal)
c.	Between pins 3& Tip	Under 2 Ω

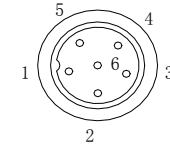

*Note: \* when checking b and c items in the table, the soldering iron must be equipped with tip.*

#### Dis-assemble the soldering iron handle

1. Turn the nut ① counterclockwise and remove the tip enclosure ②, and the tip ③.
2. Turn the nipple ④ counterclockwise and remove it from the iron.
3. Pull both the heating element (10) and the cord assembly (11) out of the handle ⑦ (Toward the tip of the iron).
4. Do not use metal tools such as pliers to remove tip or tip enclosure from-the handle.

