

KYORITSU MULTIMETER MODEL 1110

KYORITSU ELECTRICAL INSTRUMENTS WORKS,LTD.

1. Safety Warnings

This instrument has been designed and tested according to IEC Publication 61010: Safety Requirements for Electronic Measuring Apparatus. This instruction manual contains warnings and safety rules which must be observed by the user to ensure safe operation of the instrument and retain it in safe condition. Therefore, read through these operating instructions before using the instrument.

⚠ WARNING

- Read through and understand instructions contained in this manual before starting using the instrument.
- Save and keep the manual handy to enable quick reference whenever necessary.
- Be sure to use the instrument only in its intended applications and to follow measurement procedures described in the manual.
- Be sure to understand and follow all safety instructions contained in the manual.

Failure to follow the above instructions may cause injury, instrument damage and/or damage to equipment under test.

The symbol ⚠ indicated on the instrument means that the user must refer to related parts in the manual for safe operation of the instrument. Be sure to carefully read the instructions following each ⚠ symbol in this manual.

⚠ DANGER is reserved for conditions and actions that are likely to cause serious or fatal injury.

⚠ WARNING is reserved for conditions and actions that can cause serious or fatal injury.

⚠ CAUTION is reserved for conditions and actions that can cause injury or instrument damage.

4. How to Read Scales

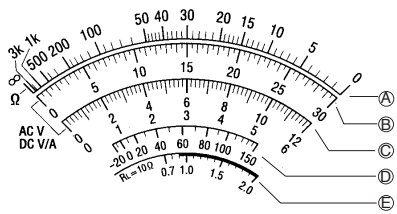

Range	Scale Used	How to Read Scale
DC.V	0.3V	B 30 × 0.01
	3V	B 30 × 0.1
	12V	C 12 × 1
	30V	B 30 × 1
	120V	C 12 × 10
AC.V	300V	B 30 × 10
	600V	C 6 × 100
	12V	C 12 × 1
	30V	B 30 × 1
DC.A	60μA	C 6 × 10
	30mA	B 30 × 1
	300mA	B 30 × 10
	300mA	B 30 × 10
Ω	× 1	A Ω × 1
	× 10	A Ω × 10
	× 100	A Ω × 100
BATT.TEST 1.5V	E 2.0	× 1
TEMP.	D	-20 ~ 150 × 1
LED		Regardless of indicated value

※ 1 : The thick portion of the scale indicates the allowable range of voltage of a battery. (The lower limit of voltage for a 1.5V dry battery specified by IEC 60086 is 0.9V.) Note that satisfactory indication on the meter may not mean the battery has enough power for high load (high current consumption) application.

5. Preparation

- **Checking Test Leads and Fuse**
Plug the red test lead into the + terminal and the black test lead into the - terminal, and set the function selector switch to a position in the Ω area. Then, short the test lead tips. When the meter pointer deflects to the right, proceed to measurement.
- **Adjusting Meter Pointer Zero**
When the meter pointer does not deflect, replace the fuse with the spare fuse, which is supplied with the instrument. If there is still no deflection, the test leads may have an open. Replace the test leads.
- **Checking Function Selector Switch Setting**
Make sure to set the function selector switch to the appropriate position. Otherwise, intended measurement cannot be made, or injury or instrument damage may result.
- **When the order of voltage or current under test is unknown, first make measurement on the highest range, and then select the appropriate range.**

6. How to Make Measurements

- ⚠ DANGER**
- Do not make measurement on a circuit above 600V AC or DC.
 - Do not apply voltage that exceeds the rated voltage of the selected range.
 - Do not turn the function selector switch during measurement.
 - Do not touch the metal parts of the test leads during measurement.
 - When the order of the voltage under test is unknown, make measurement on the highest range.
- (1) Plug the red test lead into the + terminal and the black test lead into the - terminal.
 - (2) Set the function selector switch to the appropriate DCV or ACV position.
 - (3) Connect the test leads to the circuit under test so the instrument is in parallel with the circuit. In DCV measurement, the meter pointer deflects to the right (normal direction) when the red test lead is connected to the positive side of the circuit under test and the black test lead to the negative side of the circuit. Connecting the test leads the other way will reverse the pointer deflection.
 - (4) Take reading on the appropriate scale.

⚠ DANGER

- Exercise caution not to apply voltage to the instrument set to a current range.
- Do not turn the function selector switch knob during measurement.
- Make sure to firmly connect the test leads to the circuit under test so that the connections will not become loose. The test leads must be connected to or removed from the circuit under test with the circuit powered off.
- When the order of the current under test is unknown, make measurement on the highest range.

- (1) Plug the red test lead into the + terminal and the black test lead into the - terminal.
- (2) Set the function selector switch to the appropriate DCA position.
- (3) Power off the circuit under test.
- (4) Connect the test leads to the circuit under test so the instrument is in series with the circuit. In DCA measurement, the meter pointer deflects to the right (normal

⚠ DANGER

- Make sure to set the function selector switch to the appropriate position before making measurement. Use extreme caution not to avoid applying voltage to the instrument with the range selector switch set to a current or resistance range.
- Do not attempt to make measurement in the presence of flammable gasses, fumes, vapor or dust. Otherwise, the use of the instrument may cause sparking, which can lead to an explosion.
- Never attempt to use the instrument if its surface or your hand is wet.
- Do not exceed the maximum allowable input of the selected measuring range.
- Never open the instrument when making measurement.

⚠ WARNING

- Never attempt to make any measurement if any abnormal conditions are noted, such as broken case, cracked test leads and exposed metal parts.
- Do not turn the function selector switch with test leads connected to the instrument.
- Do not install substitute parts or make any modification to the instrument. Return the instrument to Kyoritsu or your distributor for repair or recalibration.
- Do not try to replace the batteries or fuse if the surface of the instrument is wet.
- Always set the function selector switch to the OFF position before opening the instrument for battery replacement.

⚠ CAUTION

- Always make sure to insert each plug of the test leads fully into the appropriate terminal on the instrument.
- Be sure to set the function selector switch to the OFF position after use. When the instrument will not be in use for a long period of time, place it in storage after removing the batteries.
- Do not expose the instrument to the direct sun, extreme temperatures or dewfall.
- Use a damp cloth and detergent for cleaning the instrument. Do not use abrasives or solvents.

- (1) direction) when the red test lead is connected to the positive side of the circuit under test and the black test lead to the negative side of the circuit. Connecting the test leads the other way will reverse the pointer deflection.
- (2) Power on the circuit under test.
- (3) Take reading on the appropriate scale.

Resistance/Continuity Check

⚠ DANGER

- Exercise caution not to apply voltage to the instrument set to a resistance range.
- Make sure to power off the circuit under test.

- Resistance Measurement —**
- (1) Plug the red test lead into the + terminal and the black test lead into the - terminal.
 - (2) Set the function selector switch to the appropriate resistance position.
 - (3) Short the test lead tips. Turn the Ohm Zero Adjust Knob to set the meter pointer to the "0" mark on the extreme right of the scale for accurate measurement. Make this adjustment whenever the function selector switch is turned to a different resistance position. When the zero adjustment cannot be made, replace the batteries.
 - (4) Connect the test leads to the circuit under test.
 - (5) Take reading using the appropriate multiplying factor.
- Note:** Note that keeping the test lead tips shorted will exhaust the internal batteries.

- Continuity Check —**
- (1) Plug the red test lead into the + terminal and the black test lead into the - terminal.
 - (2) Set the function selector switch to the '⊘' position.
 - (3) Connect the test leads to the circuit under test.
 - (4) Check if there is a sound of the buzzer. The buzzer beeps below about 100Ω.
- Note:** The meter does not read on this range.

- LED Check —**
- (1) Plug the red test lead into the + terminal and the black test lead into the - terminal.
 - (2) Set the function selector switch to the x10 position.
 - (3) Connect the test leads to the LED under the light-up test.
 - (4) When the LED does not light up, connect the test leads the other way.
- Note:** Connect the red test lead to the anode of the LED and the black test lead to the cathode. The meter deflection has no meaning on this range.

- Temperature (TEMP.) Measurements —**
- (1) Plug the red test lead into the + terminal and the black test lead into the - terminal.
 - (2) Set the function selector switch to the x10 position.
 - (3) Short the test lead tips. Turn the Ohm Zero Adjust Knob to set the meter pointer to the "0" mark on the extreme right of the scale for accurate measurement.
 - (4) Remove both red and black test leads from the instrument.
 - (5) Plug the red lead of temperature probe Model 7060 to the + terminal and the black lead to the - terminal.
 - (6) Touch the object under test with the tip of the temperature probe and take reading on the TEMP scale.

- Battery Test (BATT. TEST 1.5V)**
This range measures the voltage of a battery, applying a load similar to that used in common applications (load resistance: 10Ω).

⚠ DANGER

- Do not apply voltage above the rated voltage for the battery test.
- Do not turn the function selector switch during a test.

- (1) Plug the red test lead into the + terminal and the black test lead into the - terminal.

2. Specifications

● Measuring ranges and accuracy (23 ± 5°C, 75%RH or less)

Ranges	Measuring Range	Accuracy	
DC.V	0.3V	0 ~ 0.3V (16.7kΩ/V)	± 3% of full scale value
	3V	0 ~ 3V	
	12V	0 ~ 12V (20kΩ/V)	
	30V	0 ~ 30V	
	120V	0 ~ 120V	
	300V	0 ~ 300V	
AC.V	600V	0 ~ 600V	± 4% of full scale value
	12V	0 ~ 12V (9kΩ/V)	
	30V	0 ~ 30V (9kΩ/V)	
	120V	0 ~ 120V	
	300V	0 ~ 300V	
DC.A	60μA	0 ~ 60μA (Terminal voltage:0.3V approx.)	± 3% of full scale value
	30mA	0 ~ 30mA (Terminal voltage:0.4V approx.)	
	300mA	0 ~ 300mA (Terminal voltage:1V approx.)※ 1	
	300mA	0 ~ 300mA (Terminal voltage:1V approx.)※ 1	
Ω	× 1	0 ~ 3kΩ (30Ω at mid-scale)	± 3% of full scale length
	× 10	0 ~ 30kΩ (300Ω at mid-scale)	
	× 100	0 ~ 300kΩ (3kΩ at mid-scale)	
BATT.TEST 1.5V	0.7 ~ 2.0V (Load resistance:10Ω approx.)	± 3% of scale length	
TEMP. ※ 2	0 ~ 100°C	± 3% of scale length	
	Ranges other than the above(-20 ~ 150°C)	± 4% of scale length	
LED	10mA approx. at 0Ω (at 3V of battery voltage)		
⊘	Buzzer beeps below about 100Ω		

- ※ 1 : Small differences may result depending on the resistance of the fuse.
 ※ 2 : With optional temperature probe MODEL 7060.
- **Standards:** IEC 61010-1
Over-voltage category CAT. III 300V, pollution degree 2
Over-voltage category CAT. II 600V, pollution degree 2
IEC 61010-2-031
IEC 61326 (EMC)
 - **Meter Movement:** Self-shielding core magnet, taut-band type
 - **Fuse:** Fast acting type(F500mA/600V), φ 6.3x32mm
 - **Overload Protection:** AC/DC600V: fused (Current/Resistance/0.3V/BATT. TEST 1.5V ranges)
AC/DC720V: 10 seconds (600/300/120V ranges)
AC/DC120V: 10 seconds (30/12V ranges)
AC/DC30V:10 seconds(3V range)
 - **Withstand Voltage:** AC3700V for one minute between internal circuit and housing case
 - **Drop Protection:** From a height of 1m onto concrete floor
 - **Operating Temperature & Humidity:** 0-40°C, relative humidity up to 85% without condensation
 - **Storage Temperature & Humidity:** -10-50°C, relative humidity up to 85% without condensation
 - **Dimensions:** 94(L) × 140(W) × 39(D)mm
 - **Weight:** Approx. 280g(including batteries)
 - **Power Source:** Two R6P(1.5V) or equivalent batteries
 - **Accessories:** Test leads MODEL 7066 1
R6P battery 2
Fuse (F500mA/600V) 2
Carrying case 1
Instruction manual 1
 - **Optional Accessories:** Temperature probe MODEL 7060

- (2) Set the function selector switch to the 'BATT. TEST 1.5V' position.
 - (3) Connect the red test lead to the positive side of the battery and the black test lead to the negative side of the battery.
 - (4) Take reading on the BATT TEST scale.
- Note:** The less power a battery has, the lower the reading on this range becomes compared to the reading on the 3V DC range.

7. Battery & Battery Replacement

⚠ WARNING

- To avoid electric shock hazard, be sure to set the function selector switch to the OFF position and remove the test leads from the instrument.
- Replacement fuse must have the following rating.
Fast acting type, F500mA/600V, φ 6.3 × 32mm

⚠ CAUTION

- Do not mix new and old batteries.
- Install the batteries observing correct polarity shown inside the instrument.

- (1) Remove the test leads from the terminals on the instrument and set the function selector switch to the OFF position.
- (2) Loosen the screw on the bottom of the instrument and remove the bottom case from the instrument.
- (3) Replace the batteries or fuse with new one(s). Use:
Two R6P dry batteries
A fast acting type fuse: F500mA/600V, φ 6.3 × 32mm
- (4) Mount the bottom case and tighten the screw.

Note: Use the spare fuse stored inside the instrument. After using the spare fuse, store a new one as a new spare.

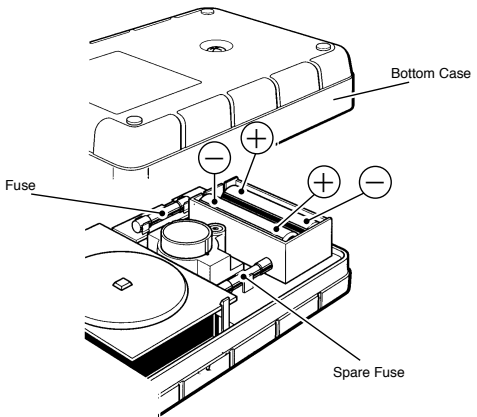

3. Instrument Layout

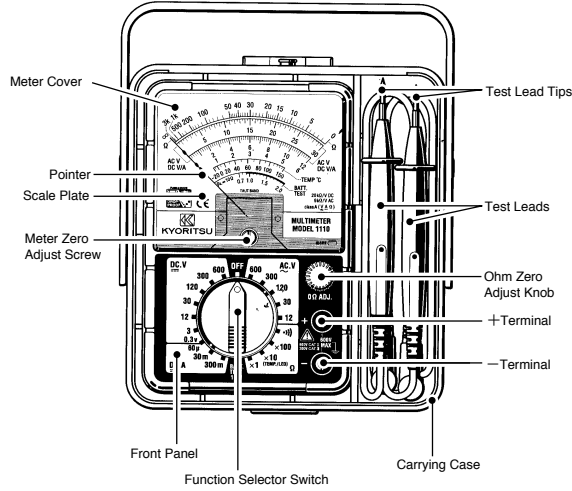

DISTRIBUTOR

Kyoritsu reserves the rights to change specifications or designs described in this manual without notice and without obligations.

KYORITSU ELECTRICAL INSTRUMENTS WORKS, LTD.
 No.5-20,Nakane 2-chome, Meguro-ku, Tokyo, 152-0031 Japan
 Phone: +81-3-3723-0131
 Fax: +81-3-3723-0152
 URL: http://www.kew-ltd.co.jp
 E-mail: info@kew-ltd.co.jp
 Factories: Uwajima & Ehime